

Pistola di lavaggio industriale

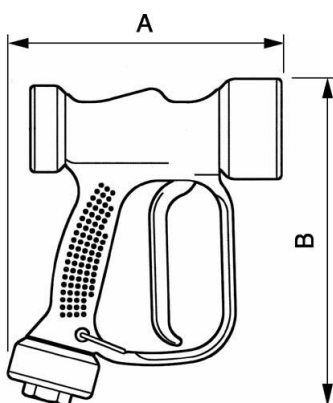

Descrizione

Riferimento	Filettatura femmina BSPP	Portata	Pressione max di utilizzo (bar)	Temperatura (max (°C))	Materiale	Peso (g)
PL JET	G 1/2	60 l/min a 24 bar 40 l/min a 10 bar	24	60 (uso continuo) +90 (uso una tantum)	Pistola di lavaggio con guaina poliammide	950



Dimensions

Riferimento	A mm	B mm
PL JET	162	216